

ELABORATION OF MICRO-HYDROPOWER STATION FOR KINETIC ENERGY CONVERSION OF FLOWING WATER

Ion Bostan, Valeriu Dulgheru, Viorel Bostan

Technical University of Moldova, 168, Ștefan cel Mare str., Chișinău, 2004,
Republic of Moldova. dulgheru@mail.utm.md

Abstract: Increased efficiency of elaborated micro-hydropower stations is achieved by an optimum position of the blades with hydrodynamic profile. The formulation used to compute the hydrodynamic forces is an inviscid–boundary layer model. Micro-hydropower station provides kinetic energy conversion of river water into mechanical or electrical energy without building barrages. Increased efficiency is provided by blades aerodynamic profile and their optimum position for efficient conversion of water kinetic energy. Two industrial prototypes are fabricated. The efficiency of the micro-hydro power stations as conversion systems of renewable energy sources kinetic energy of flowing rivers depends mostly on profiles of the hydrofoils used in the rotor's construction for interaction with fluid. The main goal of this paper consists in the elaboration of the modified hydrofoils, and based on them of the turbines with increased conversion efficiency. The following objectives were established: Elaboration of the transient computational models of the hydrodynamic turbine with 3 and 5 hydrofoils for extensive simulations in the framework of computational fluid dynamics (CFD) using software applications ICFM CFD, CFX, TurboGrid and ANSYS, that will allow a variation of the attack angle for each individual blade during a full rotor's revolution.

1. INTRODUCTION

The existence of water on the Earth has conditioned the emergence and development of life. From the times immemorial, man has chosen a place to live near rivers and lakes to meet their natural needs in water, but also for carrying out basic irrigation works. Floating or rowing led human thought by observation, to use water force and energy. Thus, the mechanical power of running water can be considered one of the oldest tools.

The means of water use and exploitation have evolved from a historical epoch to another, from one nation to another, in relation to the natural conditions, depending on the level of production relationships and forces. Thus, water energy uses has marked stages of development of the social systems from the primitive to modern society.

To avoid the construction of dams, the kinetic energy of rivers can be utilized by means of exploiting water stream turbines. This type of turbines is easily mounted, is simple in operation and maintenance cost is suitable. The 1m/s current velocity represents an energetic density of 500W/m² of the crossing section, but only a part of this energy can be drawn off and converted into useful electrical or mechanical energy. This fact depends on the type of rotor and blades. Velocity is especially important as a double increase in the water velocity can result in an eight times rising of energetic density. Prut river has a section equivalent to 60 m² and an average velocity in explorable zones of (1 – 1,3) m/s, which is equivalent to an approximate theoretical energy of (30 – 65) kW. Taking into account the fact that the turbine can occupy only a portion of the river bed the generated energy might be much smaller. There are various conceptual solutions, but the issue of increasing the conversion efficiency of water kinetic energy is in the view of researchers. The analysis of constructive versions of floatable micro-hydro power stations previously examined did not satisfy at all from the point of view of conversion efficiency of water kinetic energy. In a classical hydraulic wheel horizontal axle (Fig. 1) [1] the maximum depth at which

one of blades is sunk makes approximately 2/3 of the blade height h . Namely, only this area participates in the transformation of water kinetic energy into mechanical one. As well, the prior blade covers approximately 2/3 of the blade surface sunk utmost in the water ($h'' \approx 2/3h'$). This fact reduces significantly the water stream pressure on the blade. The blade that comes next to the blade that sunk maximally into water is covered completely by it and practically does not participate in the conversion of water kinetic energy. Therefore, the efficiency of such hydraulic wheels is small.

The insistent searches of authors lead to the elaboration and patenting of some advanced technical solutions for floatable micro-hydro power stations, based on the hydrodynamic effect, generated by the hydrodynamic profile of blades, and their orientation at optimum positions concerning the water streams with account of energy

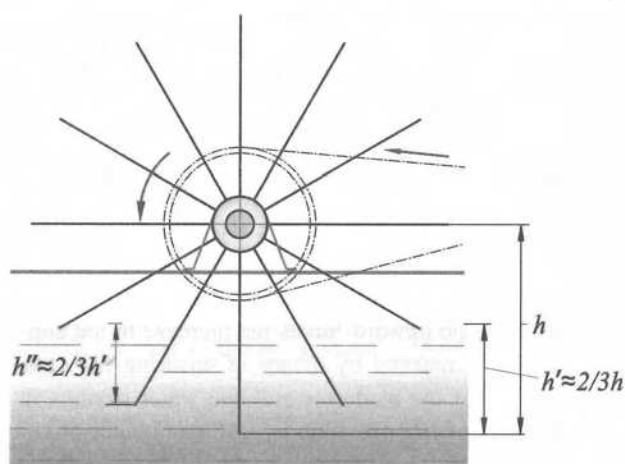

Figure 1: Conceptual diagram of the water wheel with rectilinear profile of blades

conversion in each phase of the turbine rotor rotation (Fig. 2) [1,2]. Therefore it was necessary to perform a large volume of multi-criteria theoretical research concerning the selection of optimum hydrodynamic profile of the blades and the design of the orientation mechanism towards the water streams.

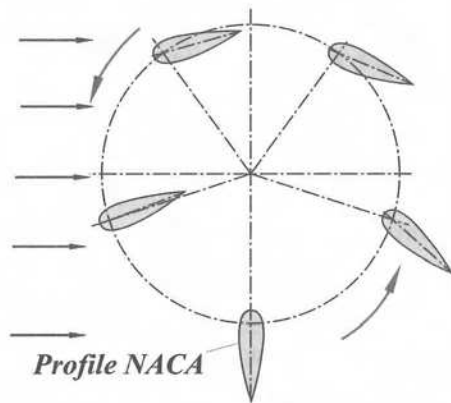

Figure 2: Conceptual diagram of the rotor with hydrodynamic profile of adjustable blades concerning the water streams.

2. Conceptual diagram of the micro hydropower plant with hydrodynamic rotor

The results of the carried out research by the authors concerning the water flow rate in the location selected for the micro-hydro power stations mounting, the geological prospecting of the river banks in the place of anchoring foundation mounting, the energetic needs of the consuming potential, represent initial data for the conceptual design of the micro-hydro power stations and its working element.

Aiming at an increase of the conversion coefficient of the water kinetic energy (Betz coefficient), a number of structural diagrams of floatable micro-hydro power plants have been designed and patented [2-7]. They comprise a rotor with pintle and vertical blades, and hydrodynamic profile in normal section. The blades are interconnected by an orientation mechanism towards the direction of the water streams. The motion of rotation of the rotor with pintle is multiplied by a mechanical transmission system and is transmitted to an electrical generator or to a hydraulic pump. The mentioned knots are fixed on a platform, mounted on floatable bodies. The platform is linked to the bank by a hinged metallic truss and by straining cables.

A very important aspect in the functional optimization of micro-hydro power plants is the selection of optimum hydrodynamic profile of the blades which allows increasing the conversion coefficient (Betz coefficient). Due to the hydrodynamic upward forces the increase in the conversion level is reached by means of ensuring the optimum position of the blade towards the water streams in various phases of rotor rotation by utilizing blades orientation mechanism. Thus, practically all blades (even those which move opposite the water streams) participate simultaneously in the generation of summary torque moment. The blades which move along the water streams utilize both hydrodynamic forces and water pressure exercised on blade surfaces for the generation of the torque moment. The blades which move opposite the water streams utilize only hydrodynamic upward forces for the generation of the torque moment. Due to the fact that the relative ve-

locity of the blades toward water streams at their motion opposite water streams is practically twice bigger, the hydrodynamic upward force is relatively big and the generated torque moment is measurable to the one generated by the water pressure. This effect forms the basis of all patented technical solutions.

The adopted technical solutions have resulted in an ample theoretical and experimental research carried out at the Centre for Renewable Energy Conversion Systems Design, Department of the Theory of Mechanisms and Machine Parts. To justify the constructive and functional parameters, supplementary digital modelling and simulation have been carried out by utilizing ANSYS CFX5.7 software. Subprograms developed by authors for the MathCAD, AutoDesk MotionInventor, etc. software, have been utilized, namely simulation of the interaction „flow-blade” of the floatable steadiness and also the optimization of blades hydrodynamic profile, with the purpose to increase the river water kinetic energy conversion efficiency for different velocities by using 3, 4 and 5 blade rotors. In the process of micro-hydro power plants design, the experience gained at research-design-manufacturing of the pilot plant was utilized.

The efficiency of micro-hydro power plant operation by private consumers for special purposes depend on the right selection of micro-hydro power plant constructive configuration and of the functional characteristics of the component aggregates participating in the process of flowing water kinetic energy conversion into useful energy. In order to satisfy the objectives and consumers demand for micro-hydro power plants, and also for the increase in the flowing water kinetic potential conversion efficiency in the certain zone of the river, the authors have designed various constructive and functional concepts based on modular assembling. The mentioned micro-hydro power plants, conceived as modular ones, allow the modification of destination and functional characteristics by replacing certain aggregates with other (generator, pump, blades with different hydrodynamic profile, 3-5 blades rotor).

Micro-hydro power plants have similar resistance structure as constructions calculated from the point of view of resistance and rigidity at dynamic demands. Floatability and maintenance of the perpendicularity of micro-hydro power plant rotor spindle for a variable river water level are ensured by technical solutions protected by patents [3-7]. The instant orientation mechanism of blades for a constant entering angle concerning the direction of the water flow represents Know-How and it is not described. The main working element on which the quantity of kinetic energy converted into useful energy depends is the blade with the hydro-dynamic profile NACA 0016, developed on the basis of the performed digital modelling. Two types of rotors with 3 and 5 blades have been designed for the mentioned micro-hydro power plants. The installed capacity of micro-hydro power plants with diameter $D = 4$ m, water-submersed blade height $h = 1,4$ m and the length of the blade cord $l = 1,3$ m for water flowing velocity $V = 1...2$ m/s can be within $P = 2...19$ kW.

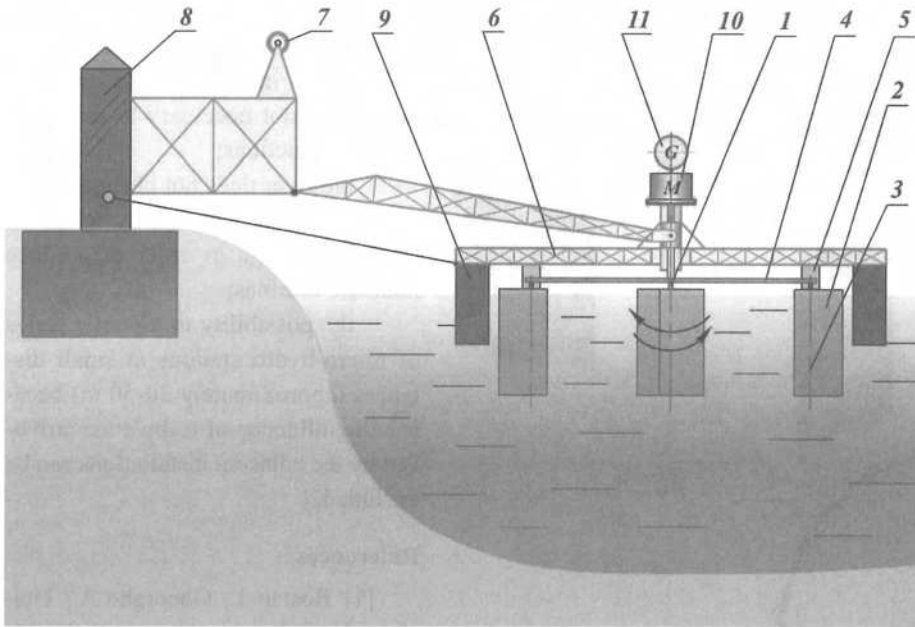

Figure 3: Floatable micro hydropower plant with blades orientation mechanism

In micro hydro power plant (Fig. 3) [3] the turbine 1 comprises blades 2, executed with the hydrodynamic profile and mounted on the axles 3, fixed by their upper part on the extreme ends of the bars 4, with the possibility to rotate around their axles. The position of the blades 2 at angle α to the direction of water flow is ensured by the controlling mechanism 5. Platform 6 is consolidated additionally by a winch 7 fixed on the truss that is mounted unshiftable on the shore pillar 8. The turbine 1 and the blades 2 are placed in the river water flow. The floating bodies 9 and the hollow blades 2 themselves control the position of turbine 1 and blades 2 concerning the water level. The multi-blade rotor is connected cinematically and coaxially to the electric generator 11 by the multiplier 10. The winch 7 is used for turbine 1 maintenance which fact requires its removal from the water. The blade 2 is positioned under angle α towards the water flow; it changes depending on the blade position to the water flow direction. The components of force F , acting on the blade, are determined from the relationships:

$$F_x = C_x \cdot \frac{\rho \cdot v^2}{2} \cdot S, \quad F_y = C_y \cdot \frac{\rho \cdot v^2}{2} \cdot S, \quad (1)$$

where: ρ is water density; v is the water flow linear velocity; s is the blade surface; C_x, C_y are lift and drag (resistance) coefficients of the blade profile. Coefficients C_x and C_y depend on the blade entering angle α (the angle between the blade and the water flow direction) and on the profile shape. The angle is determined either experimentally or by numerical calculations. The torque developed by one blade is described by the equation:

$$M = F_r \cdot \frac{d}{2} = (\cos \gamma \cdot F_y - \sin \gamma \cdot F_x) \frac{d}{2}, \quad (2)$$

where F_r is the projection of force F on the tangent drawn to the path of motion of the blade axis.

The summary torque includes the general component of the resistance force F_k . The torque moment generated by the turbine consists of the torques generated by each

separate blade. Currently only one blade will not generate positive moment (it will generate a negative moment – the resistance one). Thus, the torque generated by the proposed turbine will be essentially bigger than the torque produced by the existing turbines for the same geometrical (blades dimensions) and kinematical parameters of water. The proposed micro hydro power plant allows the transformation of the water flow kinetic energy into mechanical or electrical energy with an increased utilization coefficient of water energy.

3. Industrial prototype of micro-hydro power plant with hydrodynamic rotor

The micro-hydro power plant for river water kinetic energy conversion into electrical and mechanical energy (Fig. 4) [1,2] is poli-functional and can be utilized for street illumination, heating, water pumping for irrigation by weeping, for drainage of agricultural areas adjacent to rivers. The assembling of blades 1 with NACA 0016 profile in hydrodynamic rotor 2 and its mounting on the inlet shaft of the multiplier 3 are done in the same manner as for micro-hydro-power plant. The kinematics and constructive peculiarities of micro-hydro plant are the following: rotation motion of hydrodynamic rotor 2 with angular speed ω_p , by means of multiplier 3 and of belt drive 4 having an effective multiplying coefficient $i = 212,8$, is being multiplied up to angular working speed of the generator with permanent magnets with small rotations 5:

$$\omega_3 = \omega_1 \cdot i_1 \cdot (s^{-1}).$$

Torque moment T_3 , applied to rotor 5, is:

$$T_3 = \frac{T_1 \cdot \eta_1 \cdot \eta_2 \cdot \eta_r}{i}, (Nm),$$

where: η_1 is the mechanical efficiency of the multiplier ($\eta_1 = 0,9$);

η_2 - mechanical efficiency of the belt drive ($\eta_2 = 0,95$);

η_r - mechanical efficiency of the hydrodynamic rotor bearings ($\eta_r = 0,99$).

i - effective multiplication coefficient equal to the composition of multiplying ratios of the planetary multiplier and of the belt drive.

The electric energy produced by the generator with permanent magnets 5 (fig. 4) can be utilized both for private consumer needs of power and for supplying electricity to impeller pump 6 (CH 400), for water pumping into irrigation systems by means of weeping or drainage of agricultural areas adjacent to the rivers (by relocation of the impeller pump 6). On the basis of the conceptual diagram designed above, technical documentation was deve

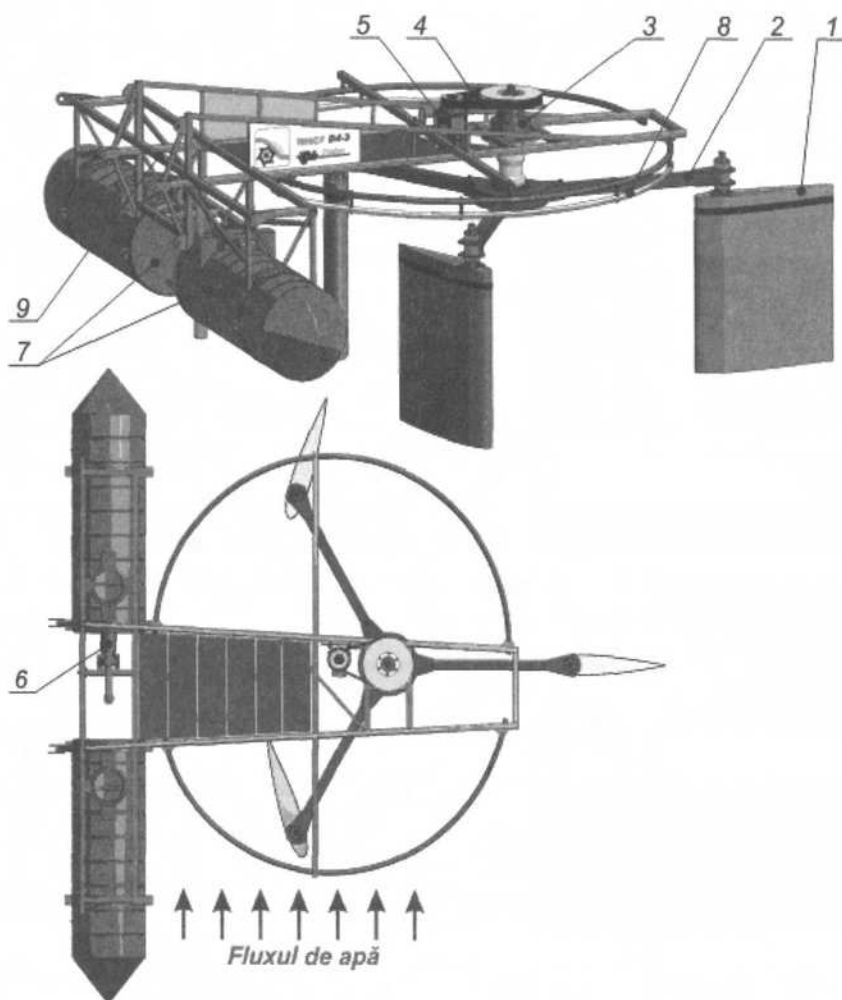

Figure 4: Micro-hydro power plant with hydrodynamic rotor river water kinetic energy conversion into electrical and mechanical energy (rotor diameter $D = 4\text{m}$, water-submersed blade height $h = 1,4\text{ m}$, length of the blade cord $l = 1,3$).

veloped industrial prototype of micro-hydro power plant for river water kinetic energy conversion into electrical and mechanical energy was manufactured.

Conclusions

In conclusion, we state that micro hydropower plants ensures the transformation of 70...86 % of the flowing water potential energy into useful electrical energy transmitted to the hydrodynamic rotor.

The basic advantages of micro-hydro power stations are as follows:

- small impact on the environment; it is not necessary to carry out civil constructions;
- the river does not change its natural course; the possibility to utilize local knowledge in order to produce floatable turbines;
- the possibility to mount a series of micro-hydro stations at small distances (approximately 30-50 m) because the influence of turbulence provoked by the adjacent installations can be excluded.

References

- [1] Bostan I., Gheorghe A., Dulgheru V., Sobor Ion, Bostan V., Sochirean A. *Resilient Energy Systems: Renewables: Wind, Solar, Hydro*. Springer Dordrecht, 2011, 515pp. ISBN 978-94-007-4189-8
- [2] Bostan I., Dulgheru V., Bostan V., Ciupercă R. *Anthology of Inventions, vol. 3. Systems for Renewable Energies Conversion (in Romanian)*. Ed.: BonsOffices SRL, 2009, 458pp.
- [3] Bostan I., Dulgheru V., Bostan V., Ciobanu O., Sochireanu A. *Hydro-electric plant*. Patent MD Nr. 601. 2013.
- [4] Bostan I., Dulgheru V., Sochireanu A., Bostan V., Ciobanu O., Ciobanu R. *Hydro-electric plant*. Patent MD Nr. 2992. 2006.
- [5] Bostan I., Dulgheru V., Bostan V., Sochireanu A., Trifan N. *Hydro turbine*. Patent MD Nr. 2993. 2006.
- [6] Bostan I., Dulgheru V., Bostan V. Sochireanu A., Ciobanu O., Ciobanu R., Dicusară I. *Hydro-electric plant*. Patent MD Nr. 3104. 2006.
- [7] Bostan I., Dulgheru V., Bostan V., Sochireanu A., Ciobanu O., Ciobanu R., (2009), *Hydro-electric station*. Patent MD Nr. 3845.